

Data Sheet

2015 v1.0

DR2100-MF-2MOD DIN Rail Multifunction Power Meter (MID Certified)

- MID B+D Certified
- Class B (kWh) EC Directive 2004/22/EC
- Certificate Number 0120/SGS0198
- Multifunction 100A Direct Connected
- Built In Pulsed & RS485 Modbus Outputs



DR2100-MF-2MOD Multifunction Power Meter

The DR2100-MF-2MOD is a new generation modern design power monitor that will measure and display electrical power quality parameters. It has been engineered to cover most applications (Single Phase networks / Built in Pulse and RS485 Modbus / Import and Export kWh), replacing the need for several different models of this power meter.

As the demand for MID certified meters has increased, we have obtained annex B and D of the EC Directive 2004/22/EC. This power meter has been tested and certified for single phase networks and import and export active energy (kWh).

The DR2100-MF-2MOD is produced to the highest quality and utilizes the latest microprocessor and technology. It has a blue backlit display and 16 different measuring parameters. With built in pulsed outputs and RS485 Modbus RTU it is fully compatible for integration with BMS and remote monitoring systems.

Parameters

- Phase to Neutral Voltage (V)
- Phase Current (A)
- Frequency (Hz)
- Power Factor (PF)
- Power Max Demand (MD kW)
- Active Power (kW)
- Reactive Power (kVAR)
- Apparent Power (kVA)
- Import Active Energy (kWh)
- Export Active Energy (kWh)
- Total Active Energy (kWh)
- Import Reactive Energy (kVARh)
- Export Reactive Energy (kVARh)
- Total Reactive Energy (kVARh)

Specifications

Measured Parameters

The unit can monitor and display the following parameters of a single phase two wire (1p2w) system.

Voltage and Current

- Phase to neutral voltages 176 to 276V a.c.
- Imin-Iref (Max) 0.5-10(100A)

This meter is certified and tested at class 1 (Accurate to within $\pm 1\%$). If the meter has a load smaller than the Imin (minimum current) we cannot guarantee class 1 accuracy.

Power factor and Frequency and Max. Demand

- Frequency in Hz
- Instantaneous power:
- Power 0 to 3600 MW
- Reactive power 0 to 3600 MVAR
- Volt-amps 0 to 3600 MVA
- Maximum demanded power since last Demand reset Power factor

Energy Measurements

Imported/Exported active energy	0 to 99999.99 kWh
Imported/Exported reactive energy	0 to 99999.99 kVARh
Total active energy	0 to 99999.99 kWh
Total reactive energy	0 to 99999.99 kVARh

Measured Inputs

Voltage inputs through 3-way fixed connector with 19mm² maximum terminal wire.

Nominal Voltage Input	(Ph+N) 176 to 276V
Max Continuous Voltage	120% of nominal
Nominal Input Current	0.5-10(100)A
Max Continuous Current	120% of nominal
Nominal Input Current Burden	0.5VA
Frequency	50Hz($\pm 10\%$)

Accuracy

Voltage	0.5% of range maximum
Current	0.5% of nominal
Frequency	0.2% of mid-frequency
Power factor	1% of unity (0.01)
Active power (W)	$\pm 1\%$ of range maximum
Reactive power (VAR)	$\pm 1\%$ of range maximum
Apparent power (VA)	$\pm 1\%$ of range maximum
Active energy (Wh)	Class 1 IEC 62053-21
Reactive energy (VARh)	$\pm 1\%$ of range maximum

Interfaces for External Monitoring

Two interfaces are provided:

- RS485 communication channel that can be programmed for Modbus RTU protocol
- Relay output indicating real-time measured energy.(configurable)

The Modbus configuration (baud rate etc.) and the pulse relay output assignments (kW/kVARh, import/export etc.) are configured through the set-up screens.

Pulse Output

The meter provides two pulsed outputs, both pulsed outputs are passive type. The first pulsed output is configurable. The pulsed output can be set to read total / import / export/ kWh / kVarh. The pulse constant can be set to generate 1 pulse per: 0.001(default) /0.01/0.1/1kWh/kVarh. The second pulsed output is non-configurable. It is fixed to read total kWh.

Rate can be set to generate 1 pulse per:
0.001 = 1 Wh/VArh (default)
0.01 = 10 Wh/VArh
0.1 = 100 Wh/VArh
1 = 1 kWh/kVarh

Pulse width 200/100/60 ms.

RS485 Output for Modbus RTU

For Modbus RTU, the following RS485 communication parameters can be configured from the set-up menu:

Baud rate 1200, 2400, 4800, 9600.

Parity none (default) / odd / even

Stop bits 1 or 2

RS485 network address 3-digit number, 1 to 247

Reference Conditions of Influence Quantities

Influence Quantities are variables that affect measurement errors to a minor degree. Accuracy is verified under nominal value (within the specified tolerance) of these conditions.

Ambient temperature	23°C ±1°C
Input waveform	50Hz ±2%
Input waveform	Sinusoidal (distortion factor < 0.005)
Auxiliary supply voltage	Nominal ±1%
Auxiliary supply frequency	Nominal ±1%
Auxiliary supply waveform (if AC)	Sinusoidal (distortion factor < 0.05)
Magnetic field of external origin	Terrestrial flux

Environment

Operating temperature	-25°C to +55°C*
Storage temperature	-40°C to +70°C*
Relative humidity	0 to 95%, non-condensing
Altitude	Up to 3000m
Warm up time	1 minute
Vibration	10Hz to 50Hz, IEC 60068-2-6, 2g
Shock	30g in 3 planes

*Maximum operating and storage temperatures are in the context of typical daily and seasonal variation.

Mechanics

DIN rail dimensions	mm x mm (WxH) per DIN 43880
Mounting	DIN rail (DIN 43880)
Sealing	IP51 indoor
Material	Self-extinguishing UL 94 V-0

Dimensions

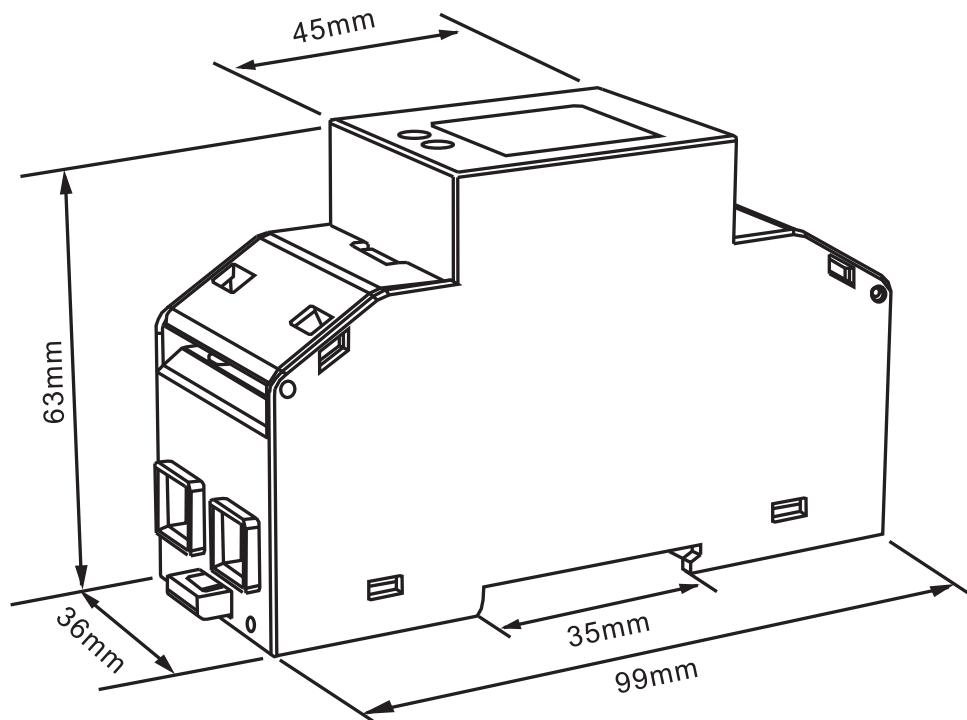

Installation

